

RevScan Flash Tabletop Temperature Sensing KIOSK

Howard **RevScan Flash** Tabletop Temperature Sensing Kiosk

This Contactless Passive Detection Temperature-Sensing kiosk helps maintain a healthy environment for employees, customers, students, visitors, and the general public. Featuring a compact tabletop design, this innovative gate-keeping solution can sense the temperature of anyone who passes through its sensors, allowing you to detect those with elevated temperatures. Designed for HR applications and ideal for businesses, schools and universities, restaurants, retailers, hospitals, clinics, and anywhere else you want to be proactive about avoiding the spread of infection.

Help safeguard your establishment from infection with kiosks from Howard and software from 22Miles

Kiosk Package

- HD Display
- Howard DR Mini-Desktop
 - Networking protection
 - Surge protection
 - Corrosion-resistant hardware
- Enclosure
 - Antimicrobial
 - Powder-coated
 - Cold-rolled steel

Software Packages

Basic

- Quick no-touch temperature scanning solution
- User operated with automated visual and audio instructions
- Streamline facility gatekeeping
- Full-solution antimicrobial defense

Premium

- Includes Basic features
- Central online portal for temperature logs
- Optionally trigger voice calls on elevated temperature
- Add-ons such as Printing or Badge Reader Integration

Receptionist

- Includes Basic and Premium features
- Connects guest through a video call with a receptionist
- Receptionist welcomes and screens the guest while the guest's temperature is displayed on screen

Specs

- Width: 18 in
- Depth: 14 in
- Height: 31.74 in
- Touchscreen: 21.5 in
- Weight: 68 lbs

Experience the Howard Interactive Kiosk Advantage today!

Howard RevScan Flash Tabletop Kiosk—Measurements & Isometric View

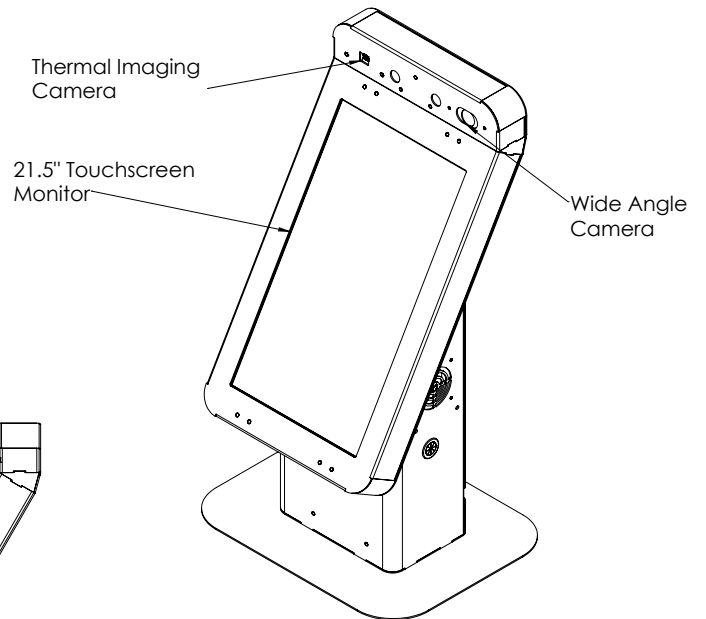
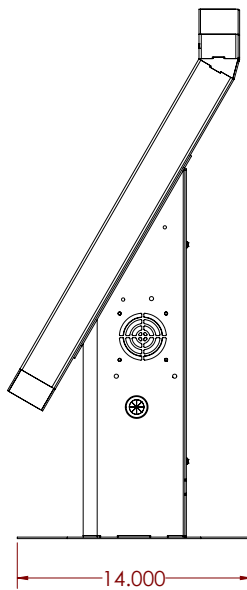
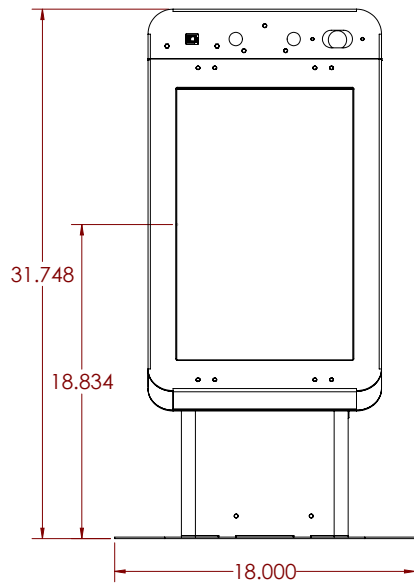
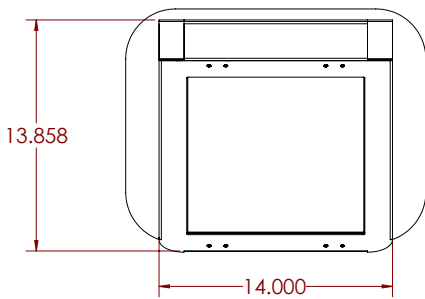

General Information
howard.com
Toll Free: 1.888.323.3151
24/7 (excluding US holidays)