



ArrivScan *mini*

Temperature Sensing KIOSK

Introducing the Howard **ArrivScan mini** Temperature Sensing Kiosk

This Contactless Passive Detection Temperature-Sensing kiosk helps maintain a healthy environment for employees, customers, students, visitors, and the general public. This innovative gate-keeping solution can sense the temperature of anyone who passes through its sensors, allowing you to detect those with elevated temperatures. Designed for HR applications and ideal for businesses, schools and universities, restaurants, retailers, hospitals, clinics, and anywhere else you want to be proactive about avoiding the spread of infection.

Help safeguard your establishment from infection with kiosks from Howard and software from 22Miles

Kiosk Package

- 13 in display
 - Camera
- Stand
 - Powder-coated steel construction
 - Small footprint
 - 4" premium dual-wheel casters with two breaking casters
 - Casters can be removed and replaced with bumpers for a stationary kiosk
 - Includes a cord wrap and cable management box

Solution Features

- Passive Detection:
 - 1 on 1 Application; visitors must walk up to the machine to be detected
- Active Detection:
 - Multiple user tracking from desk station
- Walk-Through Detection:
 - Similar to retail anti-theft devices; supports visual or audio alerts

Benefits

- Streamline facility gatekeeping
- Full-solution antimicrobial defense
- Fast, visual and audible feedback
- Active screening of open area traffic
- Easy-to-clean antimicrobial surfaces

Specs

- Width: 20 in
- Depth: 20 in
- Height: 62.6 in
- Display: 13 in
- Weight: 52 lbs

Experience the Howard Interactive Kiosk Advantage today!

Howard ArrivScan mini Kiosk-Dimensions & Isometric View

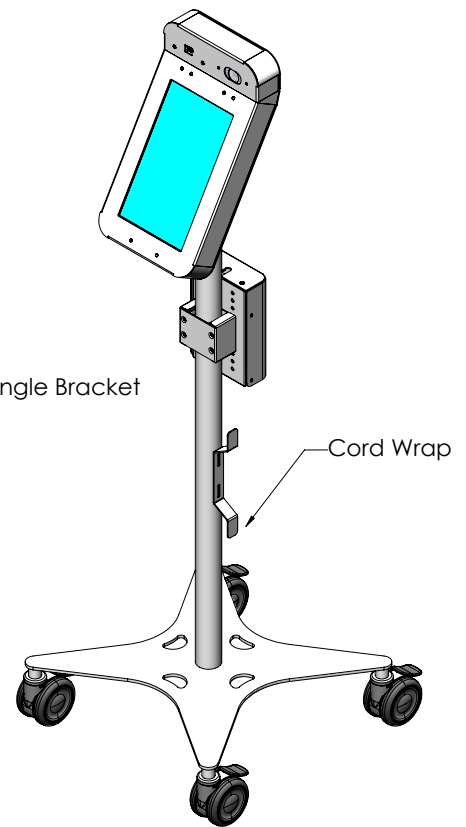
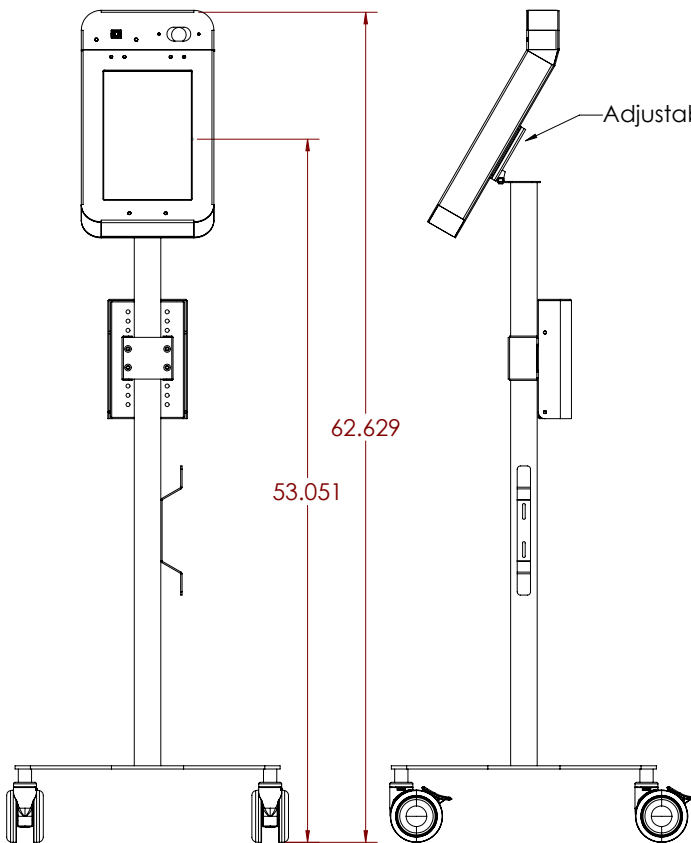
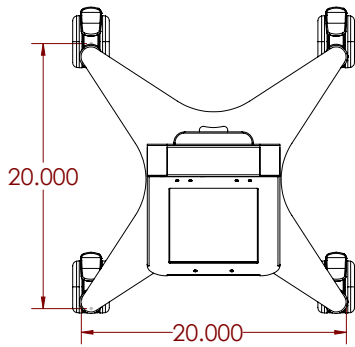

General Information
howard.com
Toll Free: 1.888.323.3151
24/7 (excluding US holidays)