

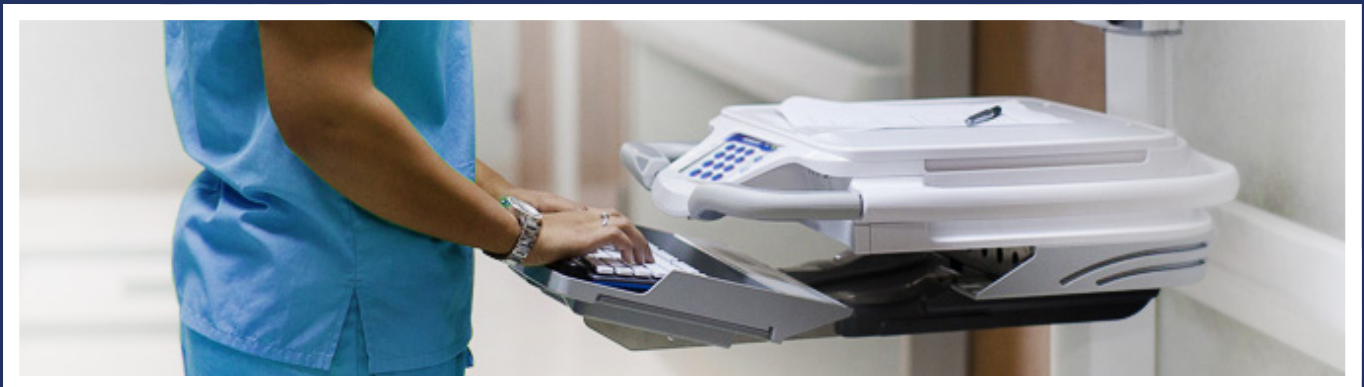

HI-Care E



HI-Care E

The HI-Care is an industry-recognized ergonomic mobile solution, with a flexible design tailored to fit multiple and varying workflows. Our most popular cart offers full class-exclusive features to automate, update, and communicate based upon the individual needs of your facility.

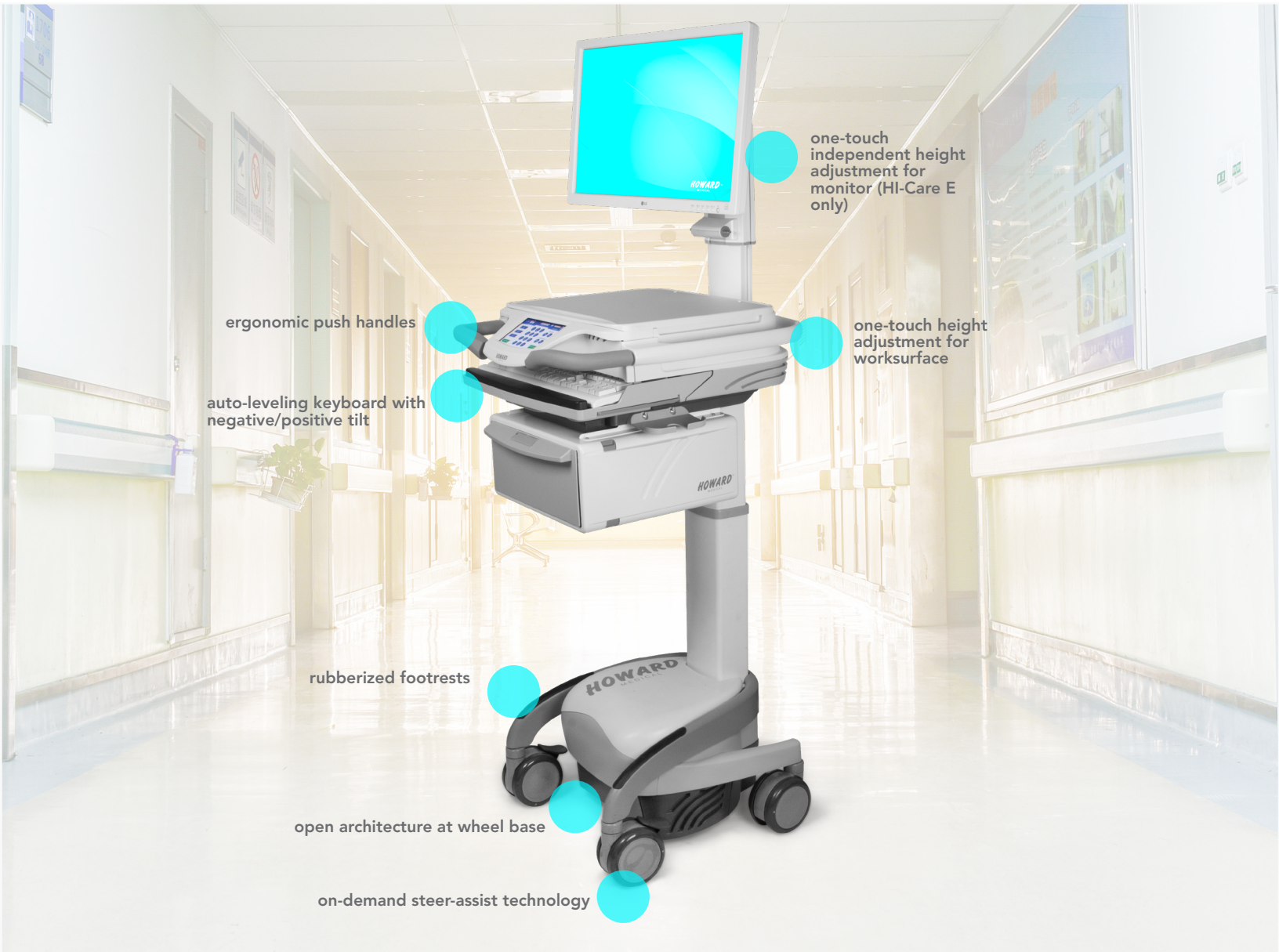

Ergonomic Features

- A short distance between the worksurface, keyboard tray, and patient bins reduces unnecessary arm movements and bending
- Ergonomic adjustable push handles with soft-touch grip on front of cart are available
- Rubberized foot rests on each side of the cart allow for a more relaxed stance and relieves fatigue
- Slide-out keyboard tray with integrated wrist rest (max keyboard dimensions 18.2" W x 7.5" D x 1.6" H)
- Keyboard is auto-leveling with a -15 degree negative-tilt and a positive-tilt up to 6 degrees
- Open architecture at wheel base allows end user to maintain their normal walking stride
- One-touch worksurface height adjustment allows for a full sit/stand range of motion
- 270° Vesa mount to allow full view swivel when maneuvering cart
- Available with on-demand steer assist technology (SAT). When SAT is engaged, the rear casters act as pivot points, easing and stabilizing the navigation, and effortlessly allows the end user to navigate around corners, doorways, and other changes in direction



Other Features Include:

- Central control panel with convenient electronic worksurface and monitor height adjustment, lighting controls and storage management
- VESA monitor mount has tilt, 270° swivel, and rotation adjustments
- Flexible storage configurations with add on capability can be customized to fit multiple workflows
- Universal accessory mounting locations on rear of cart and on monitor mount (choose from 12+ optional accessories)
- 270° wrap-around handle on sides and rear
- Large, raised-edge worksurface area (17"W x 14.3"D) with translucent protective cover
- Medical grade (all touch surfaces)
- Dedicated cable management area with easy access panels to manage and house excess cables
- Integral AC power distribution with 6 AC receptacles for powering customer equipment
- Large, fan cooled, PC compartment (17.1"W x 12.5"D x 3.2"H)
- 7 Port powered USB hub
- Battery fuel gauge
- The easy-swap cassettes allow the HI-Care cassettes to be easily swapped between the cart to a Transfer cart
- 8ft coiled power cord with hospital-grade AC plug with dual hooks integrated
- (4) 5" dual wheel premium casters (2 locking casters on front)
- Tool-less battery cover (snap-on) and tool-less battery and power supply replacement
- Available with multiple power options that you can choose from to best fit your workflow, including Howard Powermax 150
- Remote cart monitoring and management software
- Advanced electronics are an option on the HI-Care with features such as: drawer sensing, automatic drawer lighting, and drawer ajar alarm
- Mouse surface and mouse holder (left or right)
- Cart and cart accessories ship fully assembled in one box for convenience
- Meets UL and CE standards



available in:

LITE

E



Cart Dimensions

The dimensions and data below is a comparison of the various HI-Care carts and storage configurations. Contact your Howard Medical Representative for additional information.

OVERALL DIMENSIONS

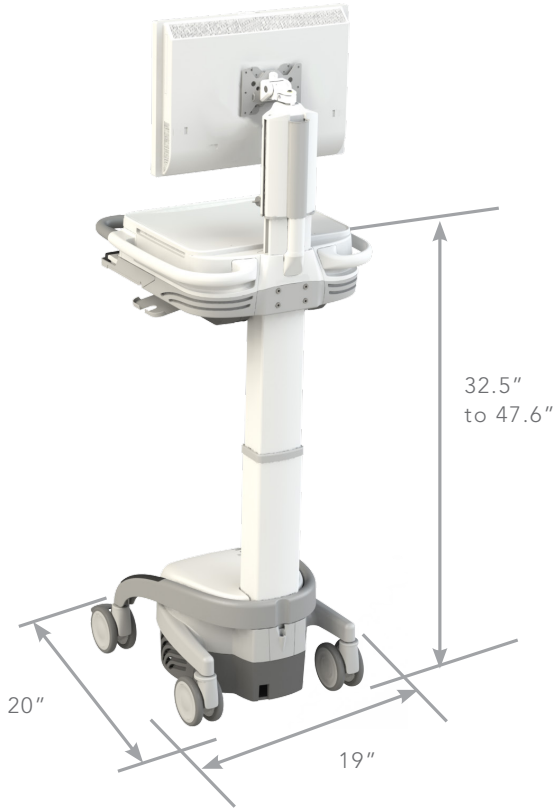

HI-Care E/Lite					
Storage		No Storage	2-Tier	4-Tier	6-Tier
Overall Dimensions (in)	Width	21.4	21.4	21.4	21.4
	Depth	23.3	23.3	23.3	23.3
Work Surface Assembly (in)	Width	21.4	21.4	21.4	21.4
	Depth	23.3	23.3	23.3	23.3
Work Surface Height Adj. (in)	Min	8.3	8.3	8.3	8.3
	Max	47.6	47.6	47.6	47.6
Base Footprint	Width	19.0	19.0	19.0	19.0
	Depth	20.0	20.0	20.0	20.0
Caster Size (in)		5.0	5.0	5.0	5.0
Writing Surface Size	Width (in)	17.0	17.0	17.0	17.0
	Depth (in)	14.3	14.3	14.3	14.3
	Area (ft ²)	1.7	1.7	1.7	1.7
Height Adj. Range (in)		15.1	15.1	13.5	6.9

PC Compartments		
PC Volume (in)	Width	17.1
	Depth	12.1
	Height	3.2

Storage Dimensions

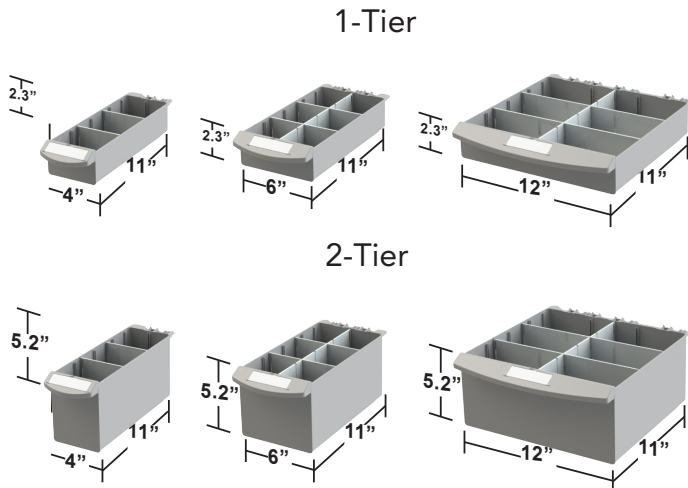

Bins		
Height	1-Tier	2.3
	2-Tier	5.2
Depth		11.0
Width	3-Across	12.0
	2-Across	6.0
	1-Across	4.0

*bin dividers are included with bins



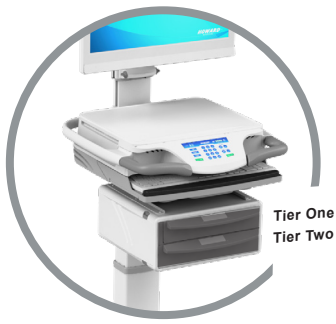

Cart Storage Features:

- Storage can easily be upgraded or reconfigured by user
- Med Drawer lighting for continuous use in low light conditions without disturbing your patient
- Programmable secure access to storage drawers and patient bins via keypad on the cart's centralized control panel
- Independent bypass key for manual emergency access
- Automatic relock with adjustable timer (6 seconds - 1 hour)
- Audible beep for code entry confirmation
- Supports up to 2000 unique user IDs (3-8 digits)
- On Screen drawer configuration and status via Med Display
- Local management of user IDs and locking system settings via Med Display
- Remote management of user IDs and locking system settings via Med Manager
- User ID, time, and date of each unlock event is stored in an audit log
- Locking system status displayed by LED's on the cart's centralized control panel
- **Powered by cart power system**
- Optional independent narcotics security
- **Configurable secure storage options**
- Patient bins are in quick swap cassettes
- Dividers included with all drawers and patient bins
- Care E Lite storage configuration must either be no storage or 2 tier storage.

HI-Care Narcotics Locking Option

- Narcotics locking option available for any storage configuration
- Bypass key included for emergency access
- Narc drawer can be a 1 or 2-tier tall drawer

Power Options

HOWARD POWERMAX 150 BATTERIES



38 AH BATTERY (STANDARD)

- 3-year lithium iron phosphate battery defect
- 3-year lithium iron phosphate battery performance
- 3-year or 3000 cycles, (battery will maintain 50% or greater of charging capacity)
- 5-year optional upgrades available
- 38 Ah / 491 Wh lithium iron phosphate battery
- 150W inverter
- Run time: 8.5 hr (full charge to 0% charge)
- Battery life expectancy: 5+ years



51 AH BATTERY

- 3-year lithium iron phosphate battery defect
- 3-year lithium iron phosphate battery performance
- Performance 3-year or 3000 cycles, (battery will maintain 50% or greater of charging capacity)
- 5-year optional upgrades available
- 51 Ah / 655 Wh lithium iron phosphate battery
- 150W inverter
- Run time: 11.5 hr (full charge to 0% charge)
- Battery life expectancy: 5+ year



Accessory Options

Howard offers several accessory mounting options and configurations that provide a smoother and more sanitary workflow. With hundreds of options and configurations available, you can tailor your cart to best fit your facility's needs and applications.

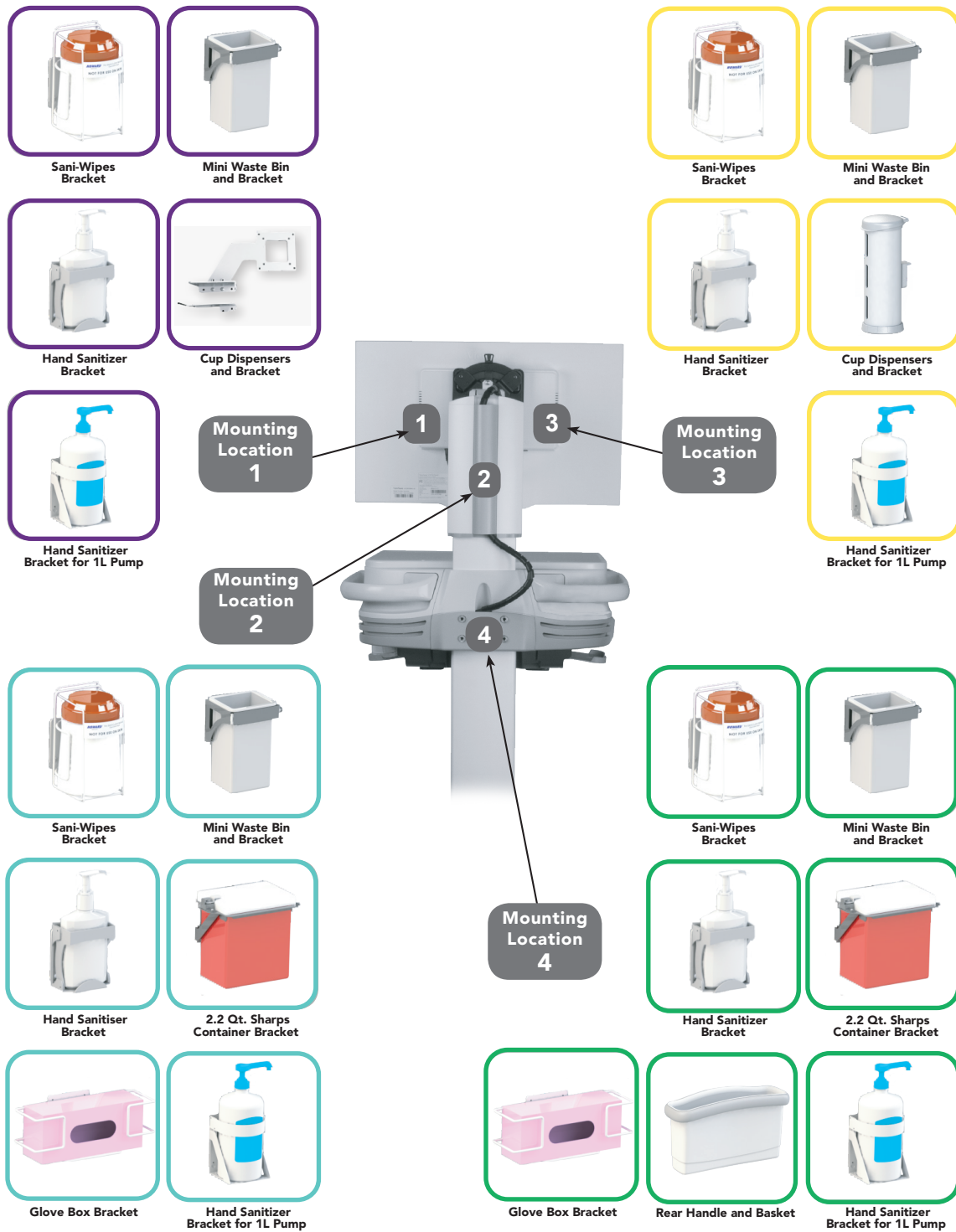

*accessory options may vary between carts

*mounting locations are not available for all Howard carts



Warranty

Howard Medical's commitment to providing unmatched customer service and support continues long after a sale is final. Our technology staff provides 24/7 technical support (excluding US holidays) for as long as you own your Howard product. Our friendly, US-based team of experts will answer your questions about the product, hardware setup, or installation, and with telephone hold times of typically less than a minute.

Standard Limited Warranty on Powered Medical Carts:

- 3-year mechanical
- 3-year electrical
- 3-year lithium phosphate battery defect
- 3-year lithium phosphate battery performance

Upgraded Limited Warranty on Powered Medical Carts:

- 5-year mechanical
- 5-year electrical
- 5-year lithium phosphate battery defect
- 5-year lithium phosphate battery performance

Computers and Other Peripheral Devices:

- See manufacturer's warranty

For our full warranty information, please visit <https://www.howardcomputers.com/support/warranties.cfm> or contact your Howard Representative.

Professional Services

The Howard Medical Professional Services Team has technical specialists nationwide and is known as one of the industry's premier service providers, with a history of successfully serving clients for more than a decade. Our dedicated employees are completely focused on customer satisfaction, giving Howard Medical the resources to provide a solution that is just right for you. Whether your project is large or small, single-site or across multiple facilities, you can trust our experience to work for you!



Deployment Consultation



In-Service Training



Technical Integration & Setup
Training / Consultation



Preventative Maintenance

- Annual Fleet Audit
- Care Protection Services Solutions
- Complete In-Factory Integration
- Equipment Cleaning With Disinfectants
- Equipment Disposal
- In-Factory Imaging
- In-Service Training

- On-Site Repair
- On-Site Troubleshooting
- Preventative Maintenance
- Technical Training
- Technology Installation
- Technical Integration & Setup Training/Consultation
- White-Glove Delivery With Trash Removal

Care Protection Service Solutions



Silver Service
Level Agreement



Gold Service
Level Agreement



Platinum Service
Level Agreement

Howard's Care Protection Service Solutions give any facility the ability to choose the level of service that works best for them. For our full services information, please visit https://www.howardcomputers.com/Support/pro_services.cfm

Howard Medical Point of Care Carts



Designed and built in Ellisville, Mississippi for over 20 years. Backed by our nationwide network of Howard Certified Technicians as well as 24/7 phone based support.

SALES REPRESENTATIVE:

TERRITORY/REGION:

EMAIL:

PHONE:

Web:
www.howard.com

Customer & Technical Support:
Toll Free: 1.888.323.3151
24/7 (excluding US holidays)

General Information:
Toll Free: 1.888.912.3151

