



D2 Kiosk

Howard D-Series D2

The Howard D2 kiosk incorporates a user-friendly platform to help customers and visitors find their way. Visiting as a newcomer can be hectic, at times, but wayfinding tools can be a key factor to improving these experiences. In addition to enhancing the visitor's overall experience, self-service kiosks can relieve employees in favor of other tasks and increase workplace efficiency in the process. Wayfinding kiosks can also be configured to promote additional services, specials, and websites.

Help users navigate destinations and encourage them to explore the surrounding area.

Basic Features

- Portrait digital signage layout
- Wi-Fi hotspot
- Camera
- Informational Messaging
- Branding options (logo, colors, etc.)
- Date/Time

Benefits

- Simplifies directing users and customers
- Enhances overall visit experience
- Show multiple path views
- 24/7 assistance
- Promotes website, specials and services

Content Features

- Digital Signage Features
- Offers Creative Services
- Web Portal Updating
- Kiosk Status Monitoring
- Usage Statistics
- Cloud Options
- On-Premise Option

Howard D2 Specs

- Width: 31 in
- Touchscreen: 42 in
- Height: 74.3 in
- Depth: 4-20 in

Experience the Howard Kiosk Advantage today!

Howard D2 Kiosk - Measurements & Isometric View

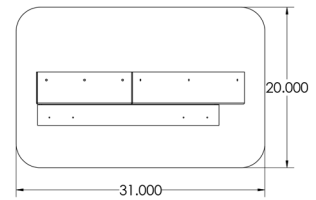
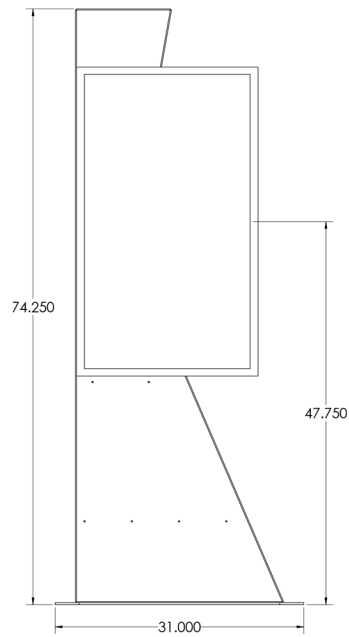
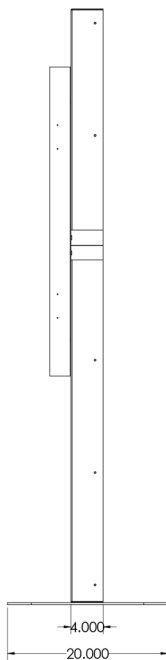
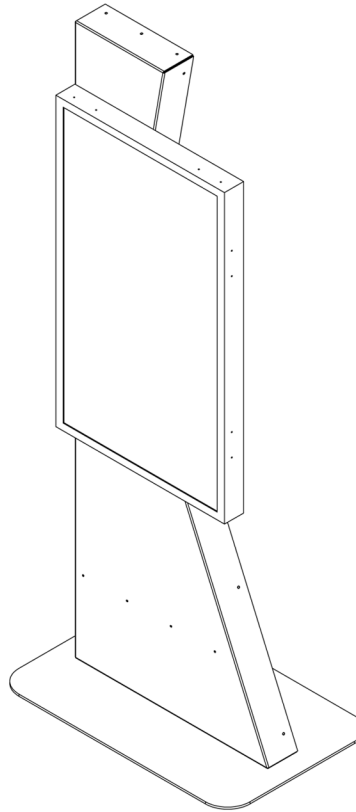

General Information
howard.com
Toll Free: 1.888.323.3151
24/7 (excluding US holidays)