

*Seeing is Believing...
Retaining and Learning*





Students are fascinated by digital image technology like the video games they play at home, but how often do they see it used in the classroom? There's a good chance that the static OHP transparencies used for presentations in your classroom aren't exciting your students anymore.

ELMO introduces the TT-02 Teacher's Tool, a presentation solution that enables you to bring the same exciting visual technology into your classroom presentations for the benefit of your students. Research shows that stimulating visual displays are easily grasped, retained and absorbed by students. Whether a scientifically based instructional program or math lesson, the TT-02 will gain the attention you need to achieve positive results.

*It's All About Sharing,
Comprehension and Student Retention*



TT-02
Teacher's Tool





What's Your District Doing About Achieving NCLB Compliance?



Scientifically proven in numerous educational white papers, improved student participation and retention are the keys to better scores on testing and NCLB reports. The lightweight and easily transportable ELMO TT-02 is offered at a budget-sensitive cost to fit any District's budget and is a great way to help start improving your students' test scores.



Create Dynamic Lessons with Ease



42.4X Zoom with Auto Focus

Optical Zoom **5.3X**

Digital Zoom **8.0X**



The 5.3X optical zoom captures crisp and detailed images. Get even closer in combination with the 8.0X digital zoom to enlarge minute features up to 42.4X. What's more, the Auto Focus function ensures that the details of objects on the TT-02's 11" x 17" shooting area remain sharp.



Simple Control Panel for Easy Operation



A logically designed control panel with simplified buttons and LEDs makes operation easy and intuitive.

Pilot lamp



Removable Stage

Provides presentation versatility



Annotate easily with the stroke of a pen using the included Removable Stage. And the fact it's removable gives you several advantages. You can write on the paper on the stage from a comfortable position. You can also take it off and move it out of the way to use the TT-02 when presenting large objects or visuals.



Versatile Input/Output Connections

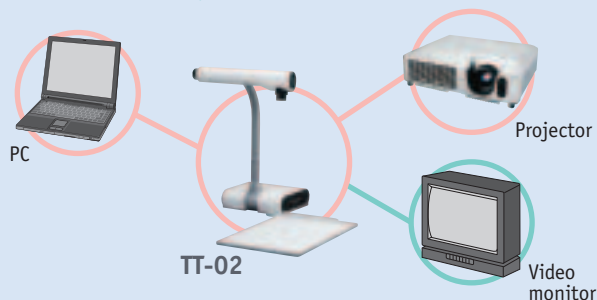

Easily switch to a PC image display or project images to any standard monitor or projector for greater presentation flexibility.



Capture Vivid Live Images

20 fps

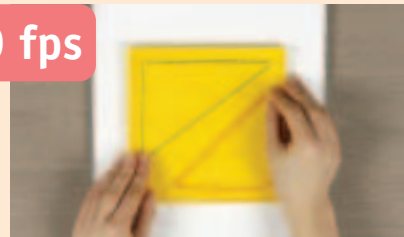

With a frame rate of 20 fps, the TT-02 smoothly captures and displays moving objects in real-time, making hands-on lessons even easier to understand.

TT-02

Teacher's Tool



Convenient, Unique Design

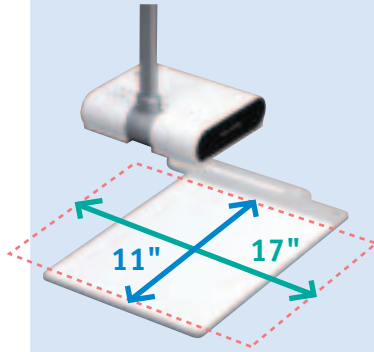

The TT-02's unique design offers the ultimate in flexibility when displaying objects and won't get in the way. Easily move documents and visuals up to 11" x 17" ledger size to display exactly what you need.



Auto Brightness Control

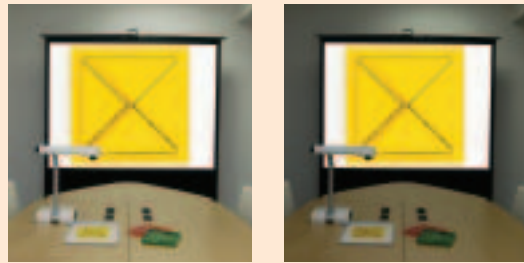

The TT-02's camera automatically adjusts to changing levels of room brightness, ensuring easy-to-view presentations, even in darkened rooms.



Microscope Viewing Mode

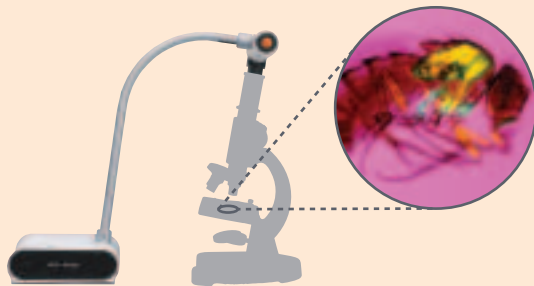

Capture microscope slides to easily display minuscule subject matter for science lessons.



Compact, Secure Storage



The TT-02's camera head conveniently swings down for compact storage, making it easy to hand-carry to any location. A security slot provides protection against theft.



(in storage)

TT-02 Specifications

Model		TT-02	
Camera	Image pick-up device	1/3" progressive scan CCD, 850,000 pixels	
	Effective pixels	1,024 (H) x 768 (V)	
	Frame rate	20 frames/sec.	
	Resolution	600 (H) x 600 (V) TV lines	
Optics	Zoom	Powered (with double speed function), 5.3X optical	
	Lens	F2.0 to 4.4, f=4.0 to 21.2 mm	
	Shooting area	Max. 16 7/8" x 12 1/2" (426 x 317 mm) Min. 3 5/8" x 2 3/4" (93 x 70 mm) for 17-inch document	
	Focus	Auto/Manual (powered)	
	Auto brightness control	Auto/Manual (powered)	
Functions	White balance	Auto/Push set/Manual	
	Negative/positive conversion	Provided	
	Color/B&W selection	Provided	
	Gamma adjustment	Provided	
	Pause mode	Provided	
	Digital zoom	Provided (8X)	
	Image rotation	Provided (0°, 180°)	
	OSD (on-screen display)	Provided	
	Text mode	Provided	
	State presetting	Up to 4 user settings	
	Free-stop arm	Provided	
	Microscope viewing mode	Provided	
	Input/output	Internal selection	Int./RGB
		Analog RGB output	XGA (1,024 x 768 @60 Hz)
Video output		Composite	
RGB input		Provided	
Others	Accessories	AC adapter, RGB cable, instruction manual, removable stage, magnet sheet, anti-glare sheet (A5 size)	
	Dimensions (W x D x H)	Set up	13 1/2" x 14 1/2" x 16 1/4" (343 x 368 x 411 mm)
		Folded	7 3/4" x 14 1/2" x 17 1/2" (195 x 368 x 444 mm)
	Weight	6.6 lbs (3.0 kg)	
	Power consumption	9W	
Power source	DC 12V (AC adapter)		

H: horizontal, V: vertical

Profile

All dimensions in inches (mm)

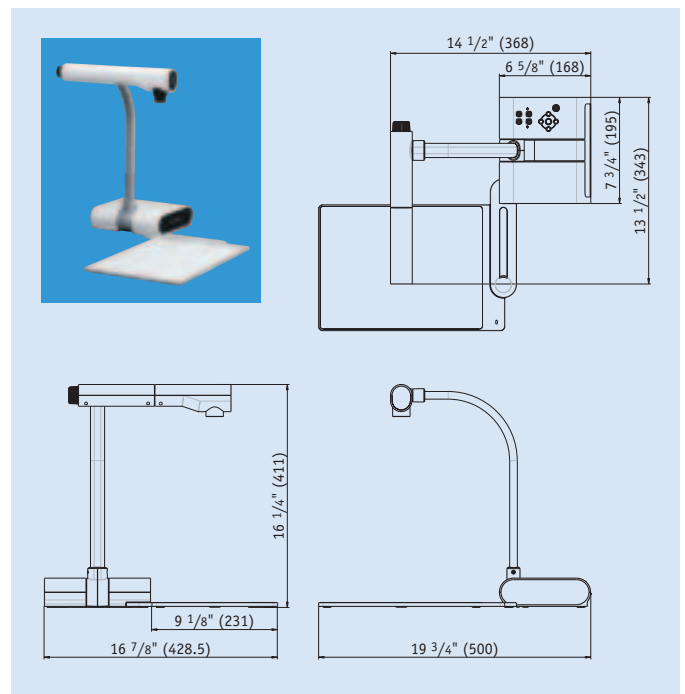

Rear Panel



HOWARD[™]
TECHNOLOGY SOLUTIONS

For more information visit www.Howard.com or call us at 888.912.3151