

A La Cart XL

Charging Cart for Chromebooks & Tablets



New!

Coming Soon!

New size designed for large Chromebooks and tablets!

Two wide handles make maneuverability easy.



Accommodates the Otterbox Defender Series case with cover!



Available fully assembled!

Heavy duty 4" casters (two locking)



PRODUCT CERTIFIED FOR LOW CHEMICAL EMISSIONS: ULCOM/GG UL 2818

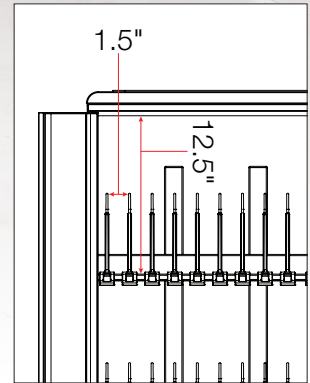

A. A La Cart XL

- The new A La Cart XL is the optimum for charging and securing the new bigger format Chromebooks and tablets, up to 32 devices with one cord to the wall.
- The integrated power distribution device prevents the power draw from overdrawing your circuit.
- Compatible with Chromebook and Otterbox Defender Series. Space for the full Otterbox Defender case with cover or other hard-cased Chromebooks.
- Sliding plastic dividers between tablet slots can be configured for wider devices. Dividers feature cable management clips and wraps. Please check required slot dimensions for your specific device. Slots measure 12.5"H x 1.5"W x 17"D.
- Vertical clearance on each charging shelf is 12.5", and depth is 17". Bottom space (4.6"H) provides storage for your AV or other equipment.
- The electronically switched AC power distribution unit allows for 12A of charging for up to 16 devices at a time. The repeating cycle timer switches automatically with 15 minutes per bank cycles to help to prevent circuit overload.
- Four ETL Listed power strips (eight outlets each) included.
- Cart exterior includes locking doors on both sides, a non-skid top, ventilated side panels, two generous handles for easy maneuverability, two auxiliary power outlets, an on/off switch, a cord winder, and heavy duty 4" casters (two locking).
- Fully assembled. TAA compliant. Has achieved GREENGUARD GOLD Certification.

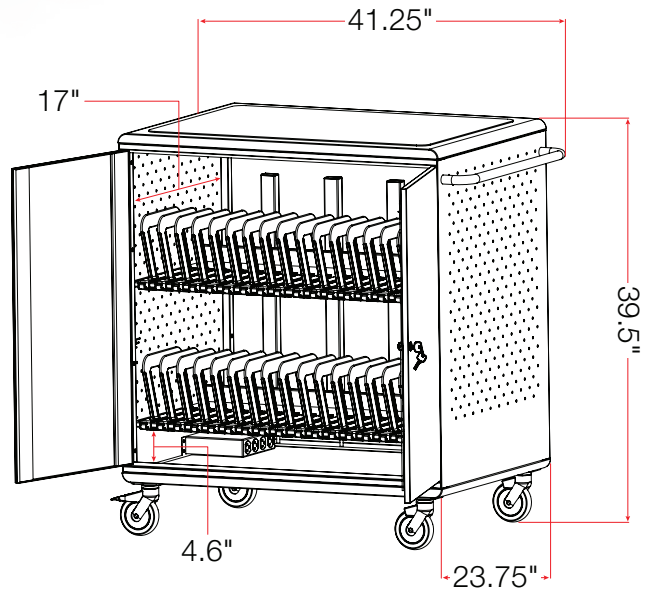

Key	Part No.	Item	Dimensions	Ship Wt.
		A La Cart XL Charging Cart for Chromebooks & Tablets		
A	27726A	A La Cart XL	39.5"H x 41.25"W x 23.75"D	112 lbs



HOWARD | TECHNOLOGY
www.howardcomputers.com | (888) 912-3151