



teacher's
pet
present-engage-teach



FINALLY, A TEACHER'S PET THAT EVERYONE LOVES

The Teacher's PET is a real favorite when it comes to progressive concepts in education, revolutionizing classroom management by optimizing and mobilizing your teaching platform. Your choice of a combination computer, projector, and document camera, securely mounted onto a sturdy, mobile base that includes a fully adjustable work surface that easily shifts for use in a standing or sitting position, makes Teacher's PET the ultimate classroom companion.

PRESENT material in the most innovative ways.

ENGAGE your students for a more fulfilling classroom experience.

TEACH them to be their best.



CART OPTIONS



Basic Model



Basic Model
with optional Howard 1637 notebook



Elmo Model
with optional monitor



Avermedia Model
with optional Howard QN1 pc

SYSTEM HIGHLIGHTS

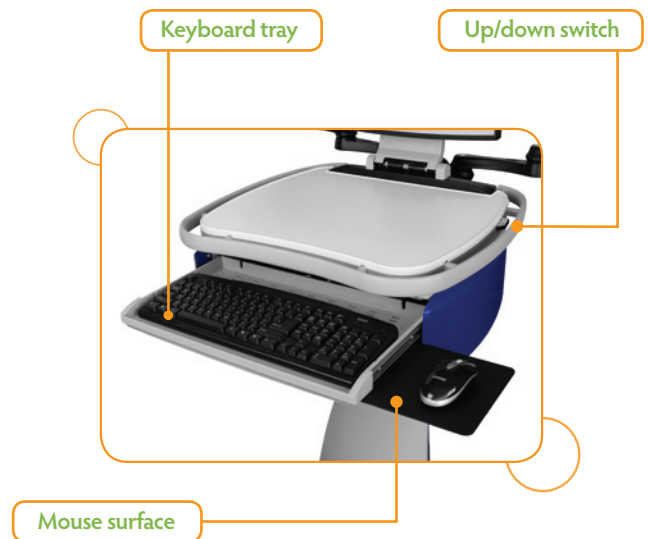

SYSTEM SPECIFICATIONS

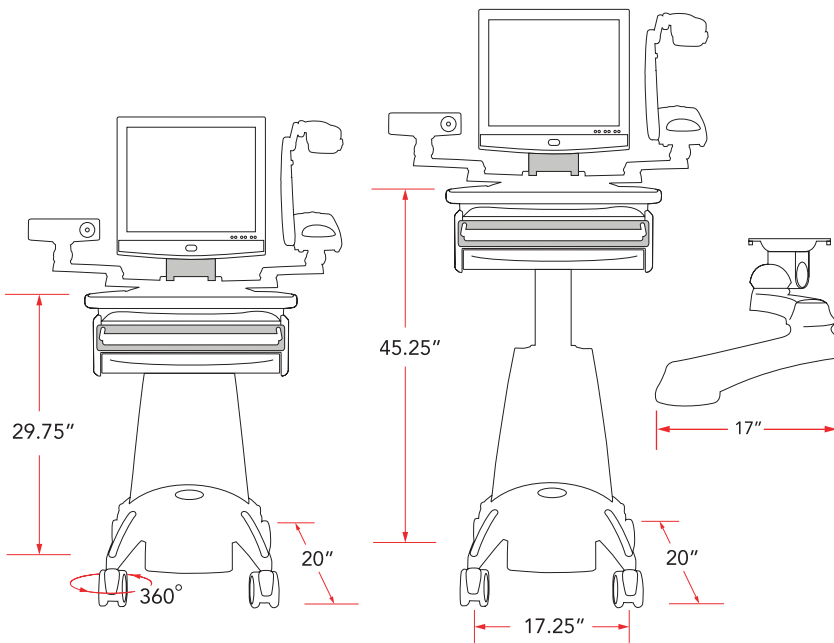

ACCESSORIES



Howard QN1 pc



QN1 touchscreen



Howard 1637 notebook

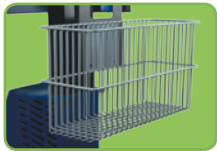

Wire basket depot



Notebook lock



Document camera

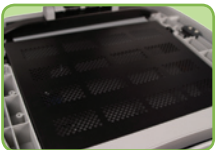

Notebook security stroud

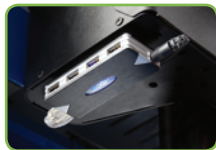

USB hub



Speaker



Drawer system



DVD/VCR combo



Web cam

SYSTEM OVERVIEWS

1. Basic Model

- One arm
- Choice of projector (Epson, Viewsonic, Toshiba)

2. Basic Model

- One arm
- Choice of projector (Epson, Viewsonic, Toshiba)
- Optional Howard 1637 notebook

3. Elmo Model

- Two arms
- Projector (Epson, Viewsonic, Toshiba)
- Elmo document camera
- Optional monitor (Viewsonic, Neovo, HP)

4. Avermedia Model

- Two arms
- Projector (Epson, Viewsonic, Toshiba)
- AverVision document camera
- Optional Howard QN1 pc

You may integrate your notebook with any cart.

5. Available on all models

- **Casters** - durable precision casters, 2 locking (front) 2 swivel (rear)
- **Power cord** - commercial grade power cord
- **Cord hanger** - used to store the cord within easy reach
- **Lift mechanism** - powerful yet quiet and smooth-operating motorized lift mechanism
- **Up/down switch** - adjust the work surface over a wide range of comfortable working heights for tall and short alike, both seated or standing
- **Keyboard tray** - slide-out keyboard snaps into place for both the in and out positions
- **Mouse surface** - extracts to either side for both right and left-handed users
- **Push handle** - convenient 270° handle lets you maneuver the cart from virtually any position
- **Work surface** - largest work surface in the industry
- **Notebook/pc compartment** - houses and protects your computer and its associated cabling

Innovation at work for you.

HOWARDTM
TECHNOLOGY SOLUTIONS
www.howard.com • 888.912.3151



BENEFITS

Adjustable monitor: Our carts feature a mounting platform for your computer that allows you to easily tilt and adjust your monitor to meet specific vision needs. Designed for bifocal wearers or anyone with end of the day eye strain, the Teacher's PET allows you to reduce overhead glare with one simple movement, keeping eyestrain to a minimum. Adjusting the monitor also facilitates easy navigation during transport times.

One-touch lift: The work surface on our carts can be easily adjusted for use while sitting or standing.

Flexibility: The Teacher's PET is built with what we term the "future ready" concept in that you can easily and cost effectively upgrade it depending on your changing needs.

Ease of movement: Because of its small footprint and dual-wheel, low-friction, 360° swivel casters, the Teacher's PET can be moved easily, requiring only 1.5 lbs of force.

Wrap-around steering: Navigating the Teacher's PET is made easier with the 270° ergonomically-designed steering handle.

Lockability: A secure surface prevents theft and tampering.

WARRANTY & SUPPORT

One (1) Year Limited Warranty

The Teacher's PET comes with a standard One (1) Year Limited Warranty. For warranty details and/or technical support, please call our toll-free number 888.323.3151.

Howard's world-class technical support team is available 7-days a week, 24-hours a day, excluding holidays.

Customer service is also available online at <http://www.howard.com/support>, by email at tech@howardcomputers.com, or by traditional mail at Howard Technology Solutions
36 Howard Drive, Ellisville, MS 39437.

FAQs

- Q: How much does the Teacher's PET weigh?**
A: The cart weighs approximately 150 pounds. Weight varies slightly depending on accessories.
- Q: Is the Teacher's PET hard to clean?**
A: No. Hard external surfaces make the Teacher's Pet extremely easy to clean and maintain using a variation of bleach, water, and mild commercial abrasives.
- Q: Will I be able to integrate future hardware on the Teacher's PET?**
A: Yes. We realized the need to easily upgrade in the future, so we have engineered technology to assist you in upgrading as needed.
- Q: What do I get when I order the Teacher's PET?**
A: The Teacher's PET is available in three configurations:
1. Howard PET cart + projector (computing device not included)
2. Howard PET cart + projector + Elmo document camera (computing device not included)
3. Howard PET cart + projector + AverVision document camera (computing device not included)
- Q: What computers are recommended for the Teacher's PET?**
A: We recommend either the Howard QN1 all-in-one or the Howard 1637 notebook. You can use one you already own as long as it fits inside the cart's PC compartment.
- Q: What choices do I have for projectors?**
A: Your projector options are: Epson 822, Epson 1815, Viewsonic PJ 550D, Viewsonic PJ 560D, Toshiba TLP 2200U, or Toshiba TDP 10U.
- Q: What will I have to do to make my PET cart operational?**
A: Prior to shipping, each PET cart is completely assembled, tested, and prepared for shipment. While all components are shipped at the same time, the projector and document scanner are detached from the base and shipped separately in order to safeguard them. After you receive your PET cart and follow the quick re-attachment instructions, simply plug the cart into a wall outlet, and your cart is ready to present.

EXPERIENCE THE HOWARD ADVANTAGE.

ABOUT US

Howard Technology Solutions, founded in 1998, is a division of Howard Industries, Inc., a billion dollar, privately held corporation headquartered in Laurel, Mississippi. With over 190,000 different product offerings ranging from desktops, notebooks, tablets, servers, printers, digital cameras, and accessories to custom lab designs and presentation carts - We provide tomorrow's technology today.

