



*Actual product may differ from image shown

TRANSFORMING COURTROOM PRESENTATIONS

Just as the double helix is the main constituent of DNA, so will the **Helix evidence presentation cart** become the crux of courtroom presentations. What can you do with this cost-effective device? Ensure physical evidence, crime scene photos, and other computer-generated information are exhibited with infallible clarity. Display digitally stored charts, testimony, and graphics in a fast-flowing format using a variety of software. Locate deposition transcripts within seconds. Available in four convenient models, select the cart that best serves your technology needs. Your choice of a combination computer, projector, and document camera securely mounted onto a sturdy, highly ergonomic mobile base makes this a smart addition to the trial process. Who wins with the timesaving Helix? From judges and jury to counsel and onlookers, virtually all who enter the courtroom will benefit from this advancement in litigation.



CART OPTIONS



Basic Model

Basic Model
with optional Howard notebook

Elmo Model
with optional monitor

Avermedia Model
with optional Howard all-in-one pc

SYSTEM HIGHLIGHTS

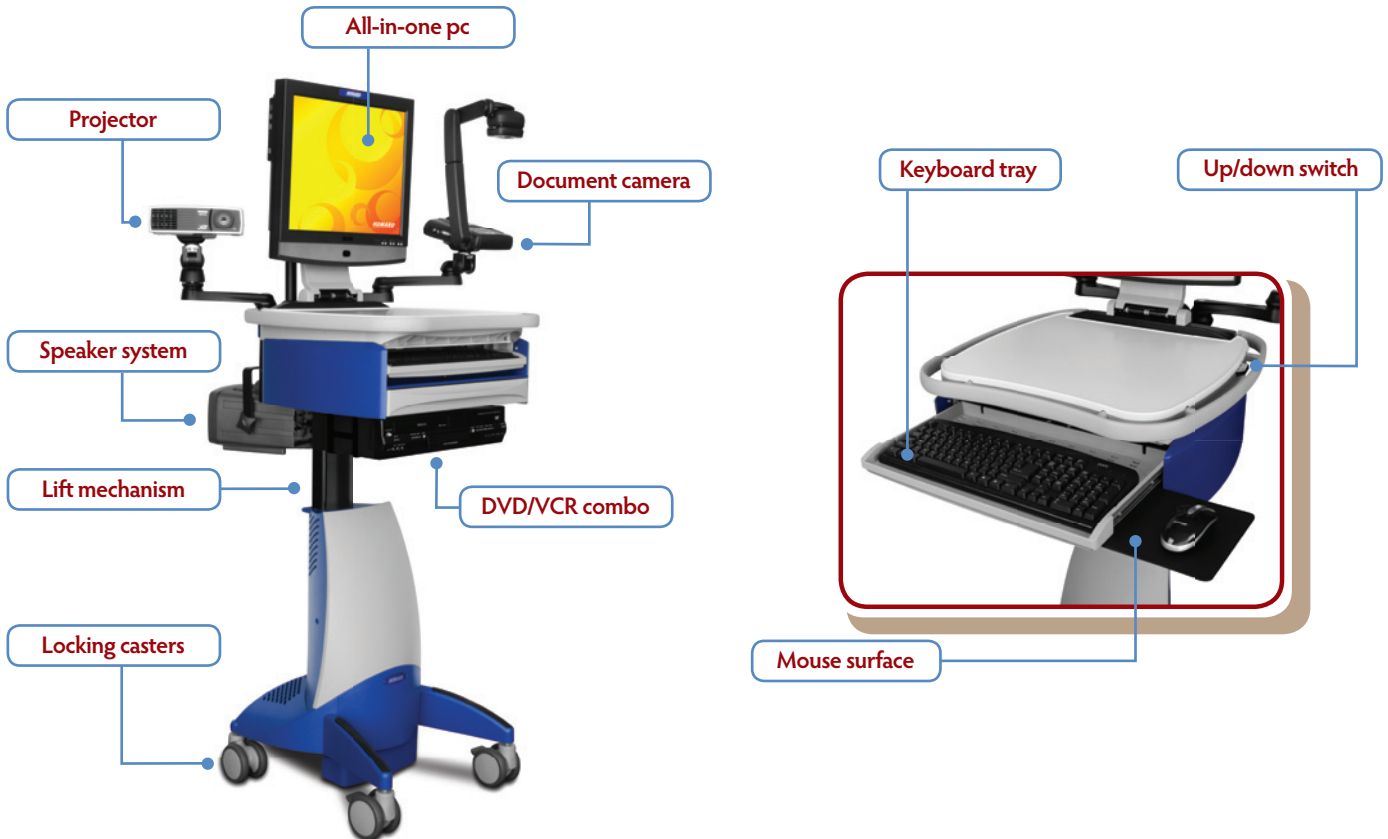

SYSTEM SPECIFICATIONS

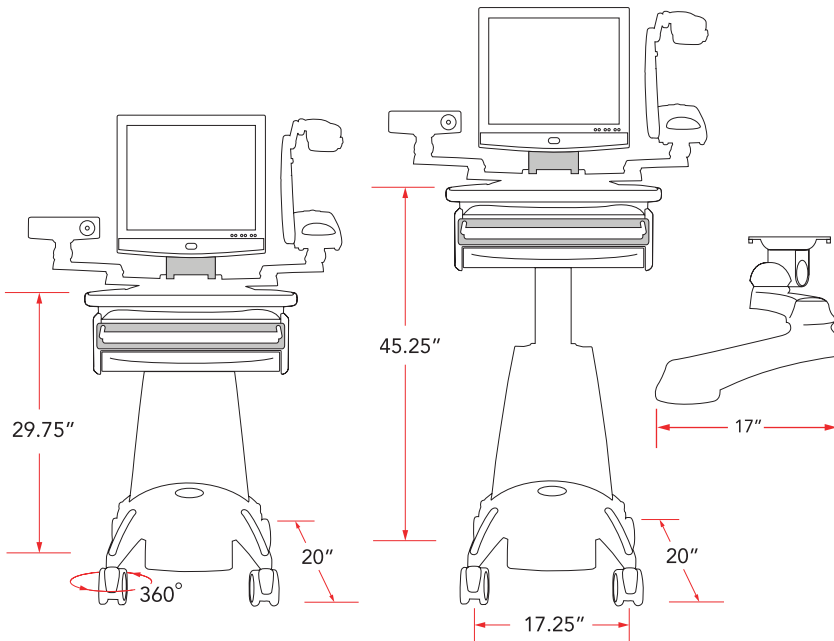

ACCESSORIES*



Howard all-in-one pc



All-in-one touchscreen



Howard notebook

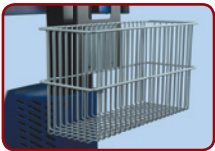

Wire basket depot



Notebook lock



Document camera

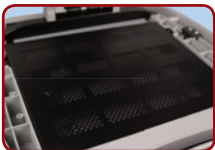

Notebook security stroud



USB hub



Speaker



Drawer system



DVD/VCR combo



Web cam

*Actual product may differ from image shown

SYSTEM OVERVIEW

1. Basic Model

- One arm
- Choice of projector (Epson, Viewsonic, Toshiba)

2. Basic Model

- One arm
- Choice of projector (Epson, Viewsonic, Toshiba)
- Optional Howard notebook

3. Elmo Model

- Two arms
- Projector (Epson, Viewsonic, Toshiba)
- Elmo document camera
- Optional monitor (Viewsonic, Neovo, HP)

4. Avermedia Model

- Two arms
- Projector (Epson, Viewsonic, Toshiba)
- AverVision document camera
- Optional Howard all-in-one pc

You may integrate your notebook with any cart.

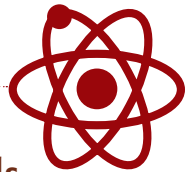

5. Available on all models

- **Casters** - durable precision casters, 2 locking (front) 2 swivel (rear)
- **Power cord** - commercial grade power cord
- **Cord hanger** - used to store the cord within easy reach
- **Lift mechanism** - powerful yet quiet and smooth-operating motorized lift mechanism
- **Up/down switch** - adjust the work surface over a wide range of comfortable working heights for tall and short alike, both seated or standing
- **Keyboard tray** - slide-out keyboard snaps into place for both the in and out positions
- **Mouse surface** - extracts to either side for both right and left-handed users
- **Push handle** - convenient 270° handle lets you maneuver the cart from virtually any position
- **Work surface** - largest work surface in the industry
- **Notebook/pc compartment** - houses and protects your computer and its associated cabling

Innovation at work for you.

HOWARD[™]
TECHNOLOGY SOLUTIONS

BENEFITS

Adjustable monitor: Our carts feature a mounting platform for your computer that allows you to easily tilt and adjust your monitor to meet specific vision needs. Designed for bifocal wearers or anyone with end of the day eye strain, Helix allows you to reduce overhead glare with one simple movement. Adjusting the monitor also facilitates easy navigation during transport times.

One-touch lift: The work surface on our carts can be easily adjusted for use while sitting or standing.

Flexibility: Helix is built with what we term the "future ready" concept in that you can easily and cost effectively upgrade it depending on your changing needs.

Ease of movement: Because of its small footprint and dual-wheel, low-friction, 360° swivel casters, Helix can be moved easily, requiring only 1.5 lbs of force.

Wrap-around steering: Navigating the Helix is made easier with the 270° ergonomically designed steering handle.

Lockability: A secure surface prevents theft and tampering.

WARRANTY & SUPPORT

One (1) Year Limited Warranty

Helix comes with a standard one (1) year limited warranty. For warranty details and/or technical support, please call our toll-free number, 888.323.3151.

Howard's world-class technical support team is available 7-days a week, 24-hours a day, excluding holidays. Visit our website for a list of holidays.

Customer service is also available online at <http://www.howard.com/support>, by email at tech@howardcomputers.com, or by traditional mail at Howard Technology Solutions
36 Howard Drive, Ellisville, MS 39437.

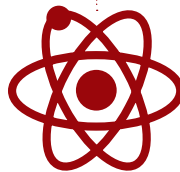

FAQ's

Q: How much does Helix weigh?

A: The cart weighs approximately 150 pounds. Weight varies slightly depending on accessories.

Q: Is Helix hard to clean?

A: No. Hard external surfaces make our Helix extremely easy to clean and maintain using a variation of bleach, water, and mild commercial abrasives.

Q: Will I be able to integrate future hardware on Helix?

A: Yes. We realized the need to easily upgrade in the future, so we have engineered technology to assist you in upgrading as needed.

Q: What do I get when I order Helix?

A: Helix is available in three configurations:

1. Howard Helix cart + projector (computing device not included)
2. Howard Helix cart + projector + Elmo document camera (computing device not included)
3. Howard Helix cart + projector + AverVision document camera (computing device not included)

Q: What computers are recommended for Helix?

A: We recommend either a Howard all-in-one solution or one of our Howard notebooks. You can use one you already own as long as it fits inside the cart's PC compartment.

Q: What choices do I have for projectors?

A: Your projector options include the Epson 822, Epson 1815, Viewsonic PJ 550D, Viewsonic PJ 560D, Toshiba TLP 2200U, or the Toshiba TDP 10U.

Q: What will I have to do to make my Helix cart operational?

A: Prior to shipping, each Helix cart is completely assembled, tested, and prepared for shipment. While all components are shipped at the same time, the projector and document scanner are detached from the base and shipped separately in order to safeguard them. After you receive your Helix cart and follow the quick re-attachment instructions, simply plug the cart into a wall outlet and your cart is ready to present.

EXPERIENCE THE HOWARD ADVANTAGE.

ABOUT US

Howard Technology Solutions, founded in 1998, is a division of Howard Industries, Inc., a billion dollar, privately held corporation headquartered in Laurel, Mississippi. With over 190,000 different product offerings ranging from desktops, notebooks, tablets, servers, printers, digital cameras, and accessories to custom lab designs and presentation carts, provide tomorrow's technology today.

